



FIG. 1

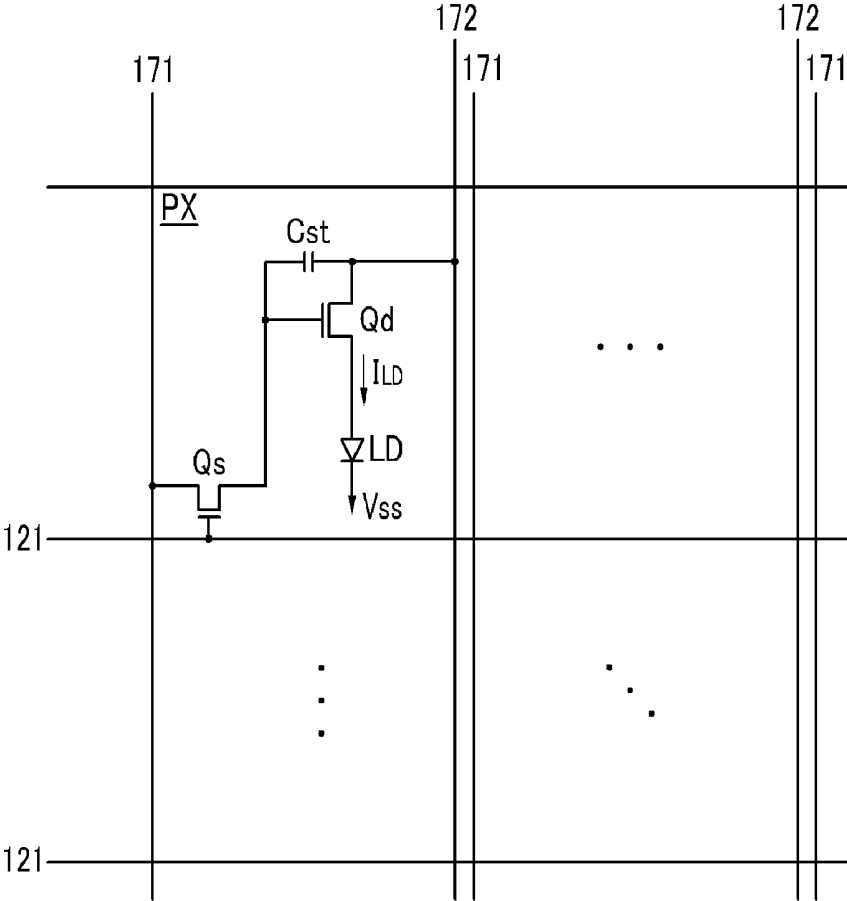



FIG. 3

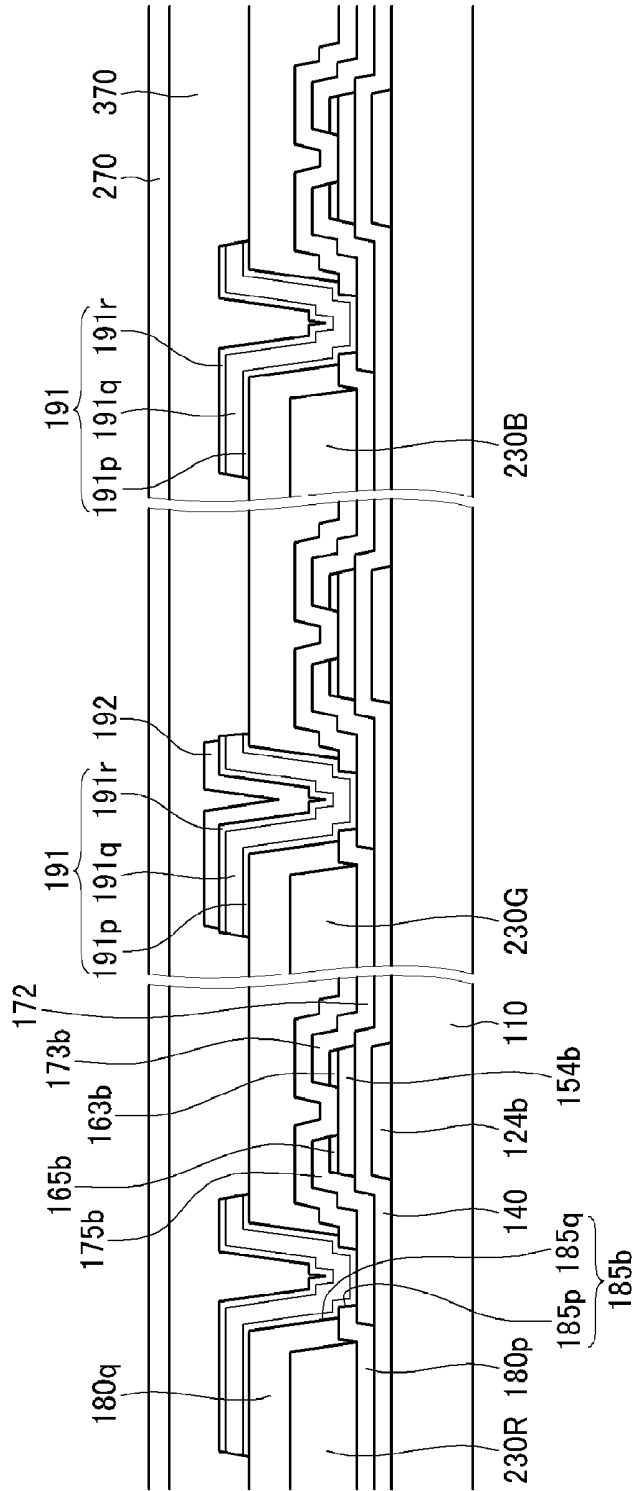

FIG. 4

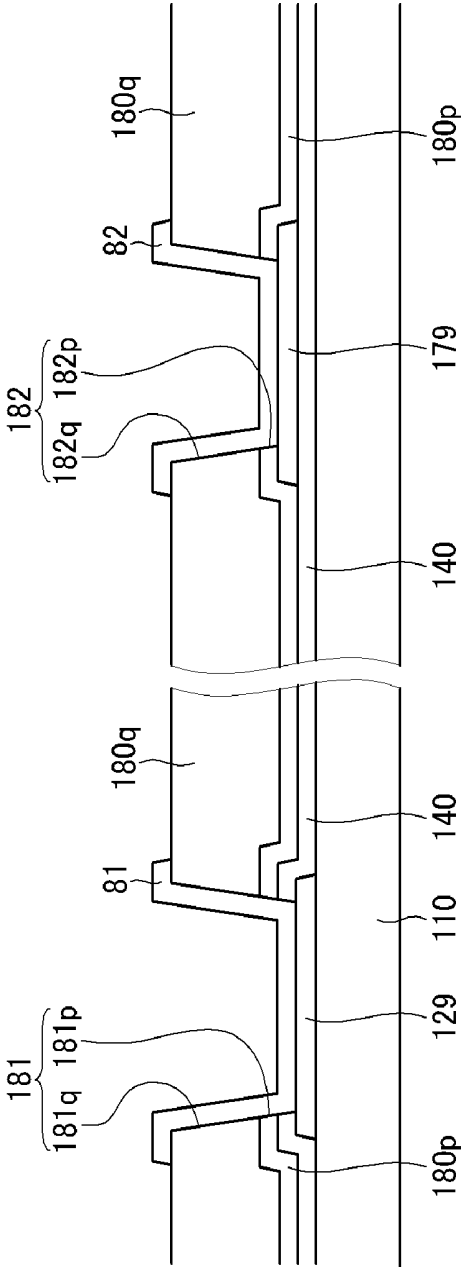

FIG. 5

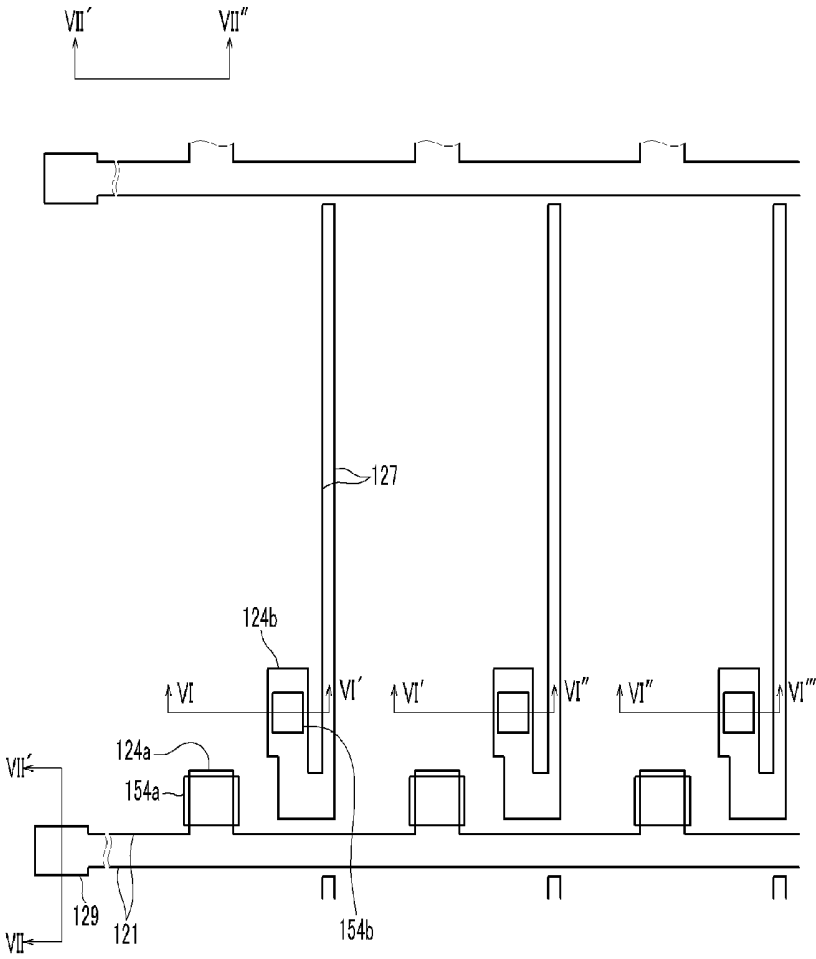

FIG. 6

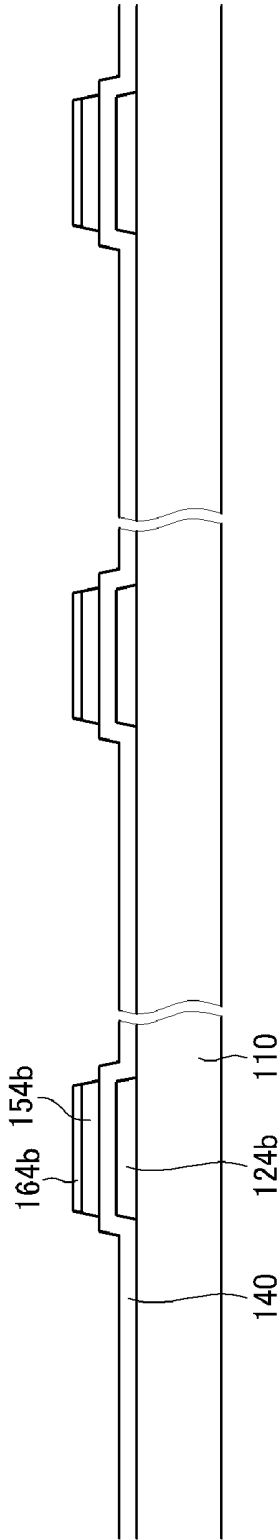

FIG. 7

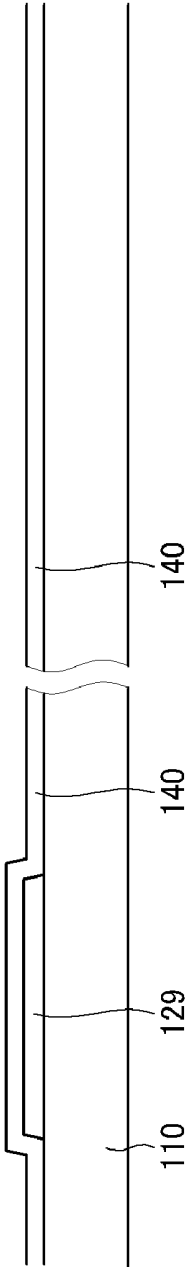

FIG. 8

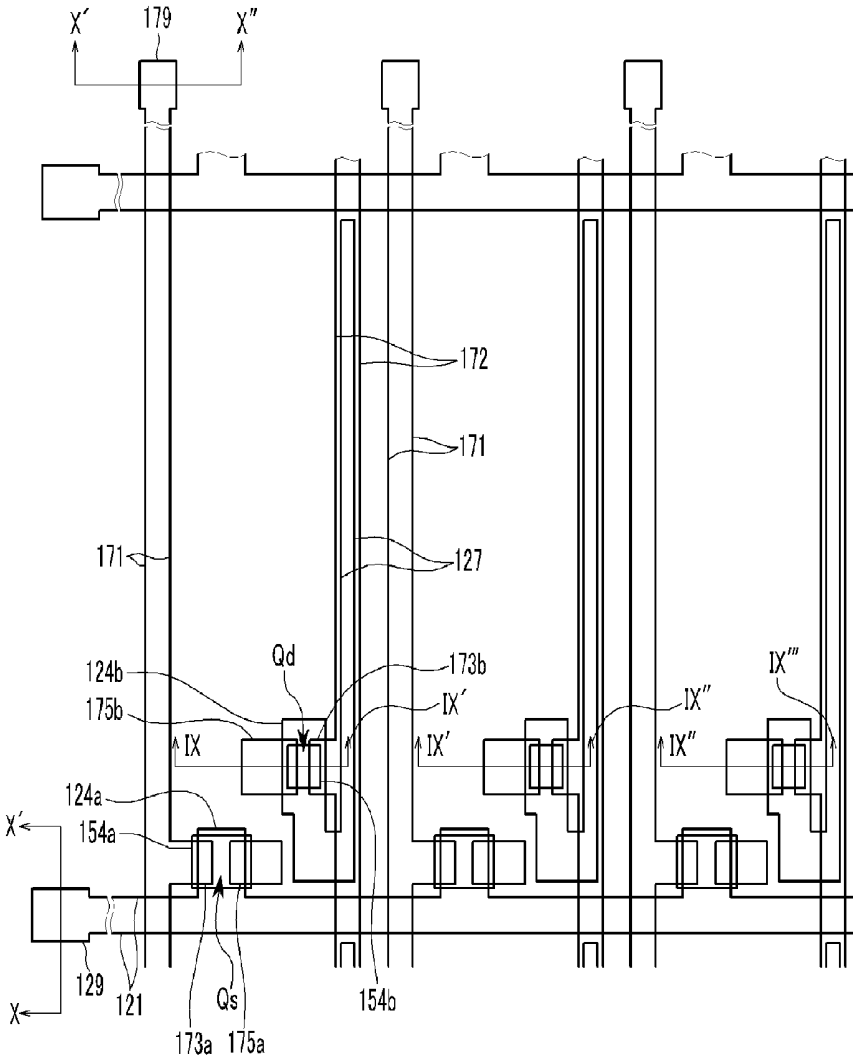

FIG. 9

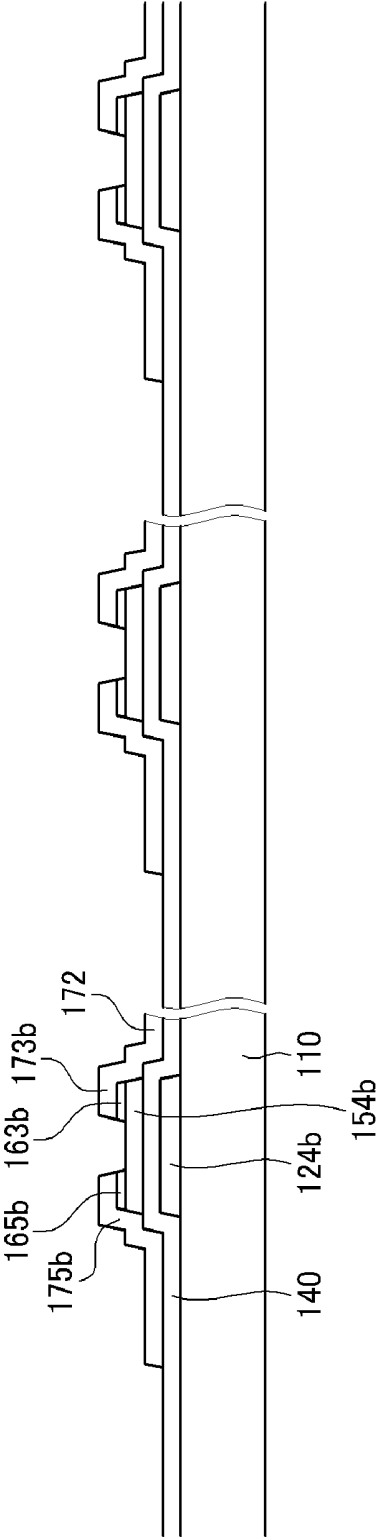

FIG. 10

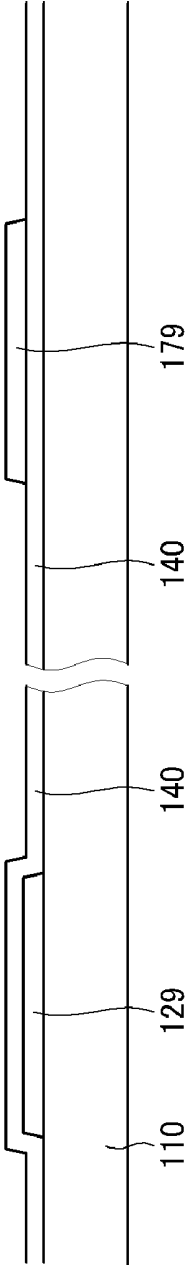

FIG. 11

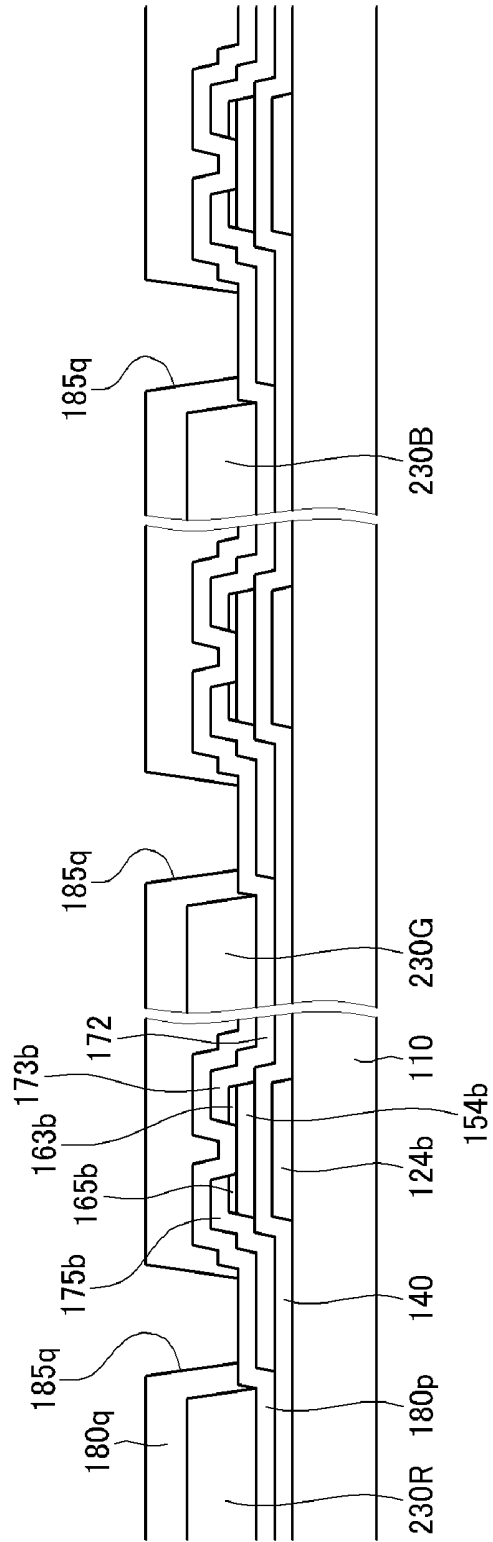

FIG. 12

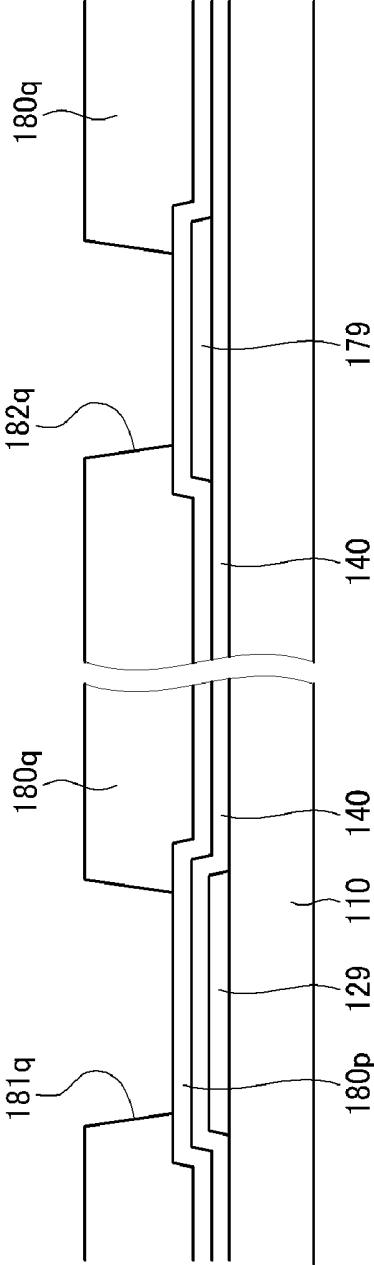



FIG. 14

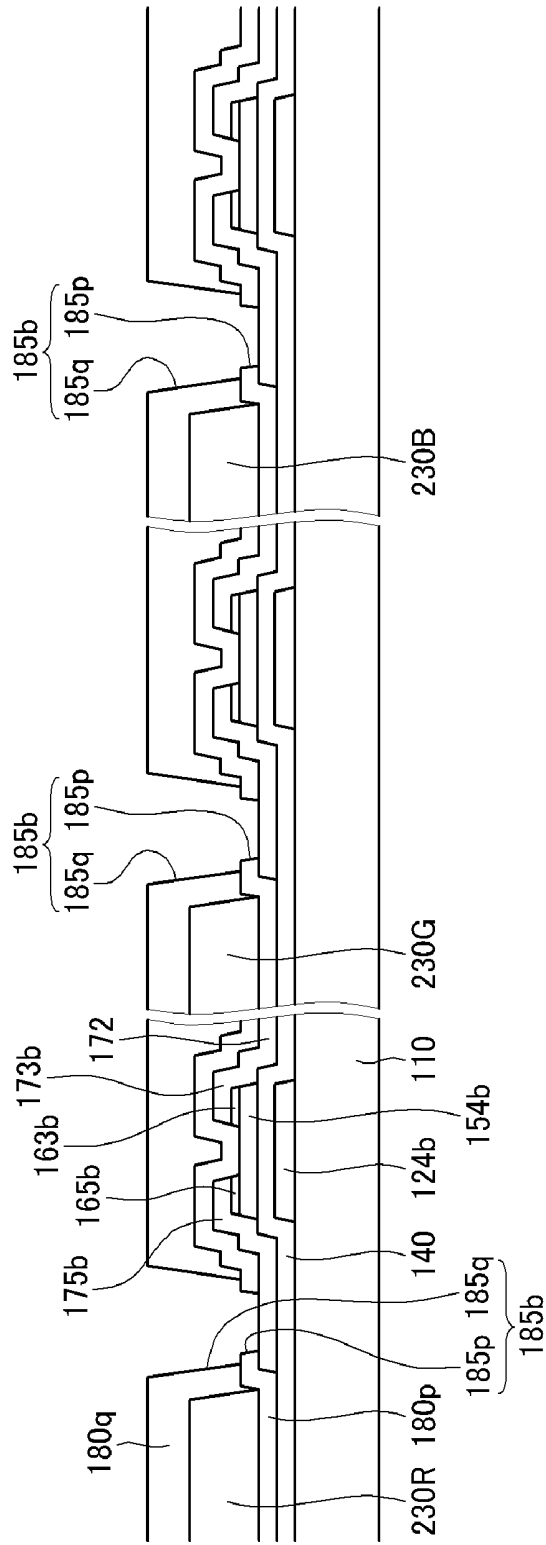

FIG. 15

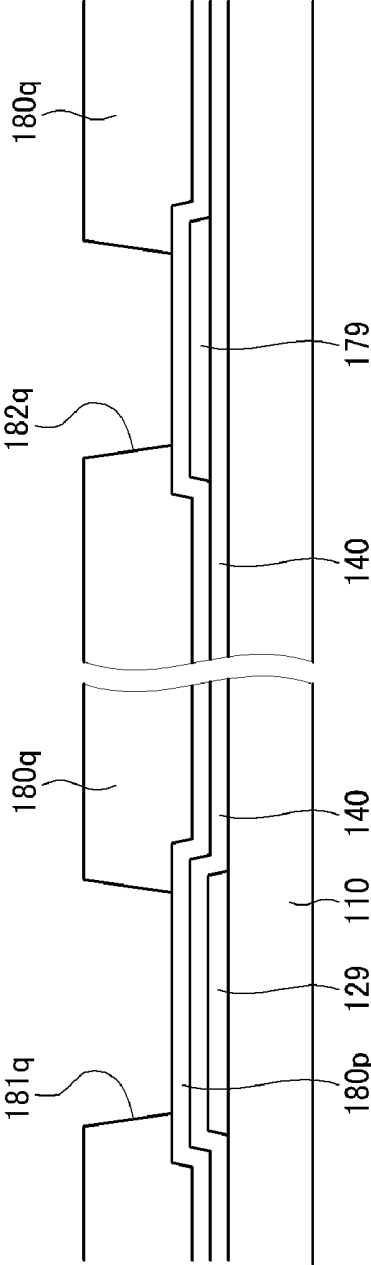

FIG. 16

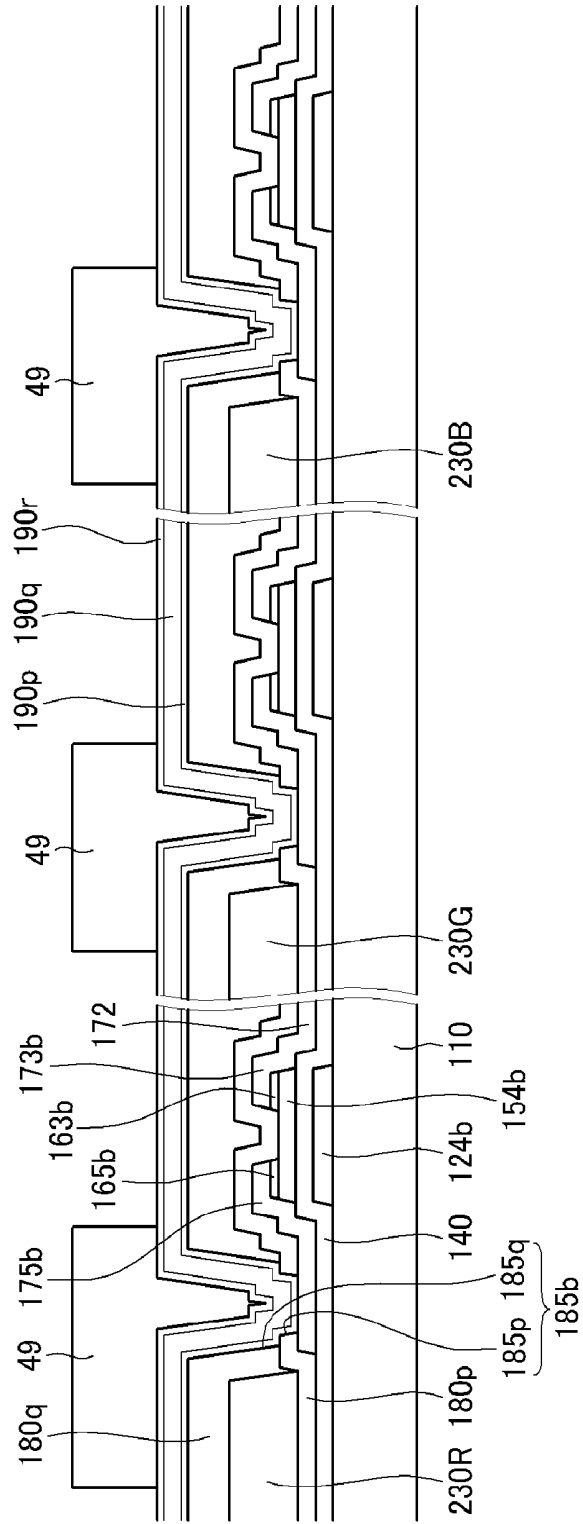

FIG. 17

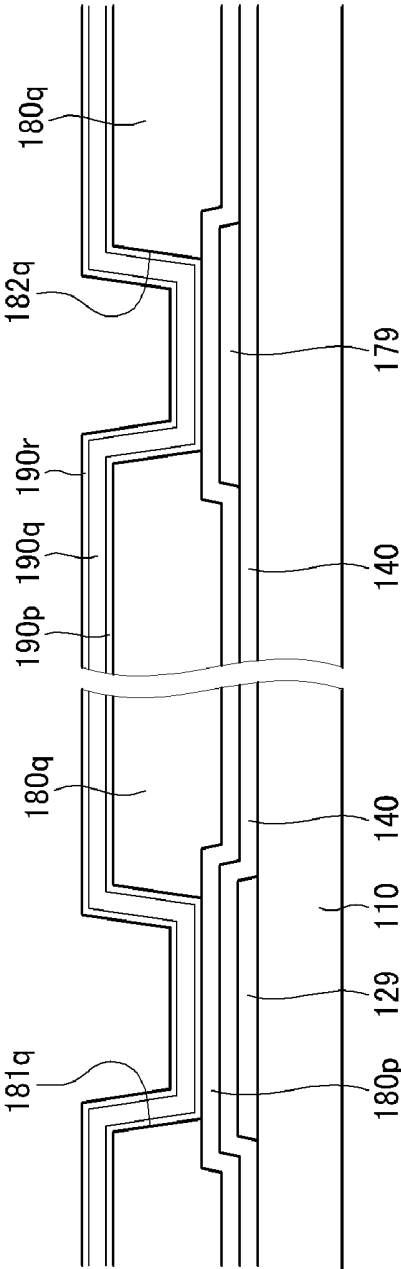



FIG. 19

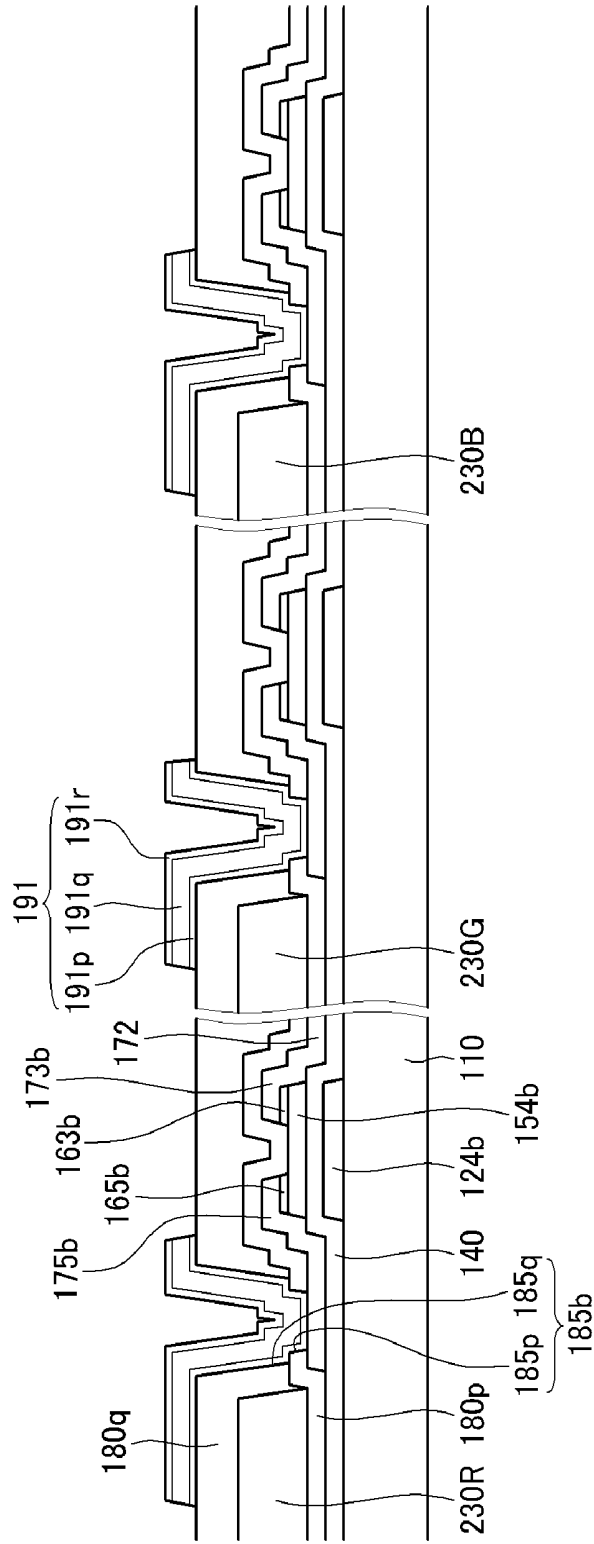

FIG. 20

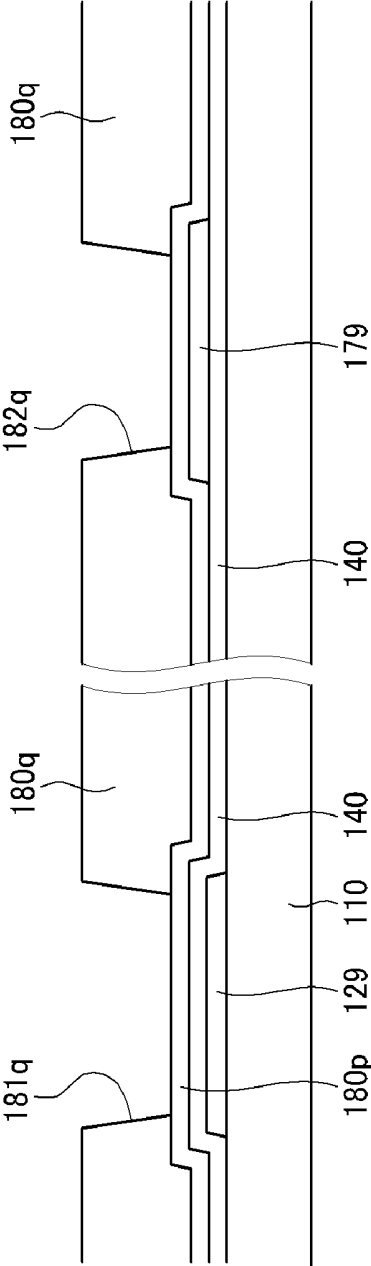



FIG. 22

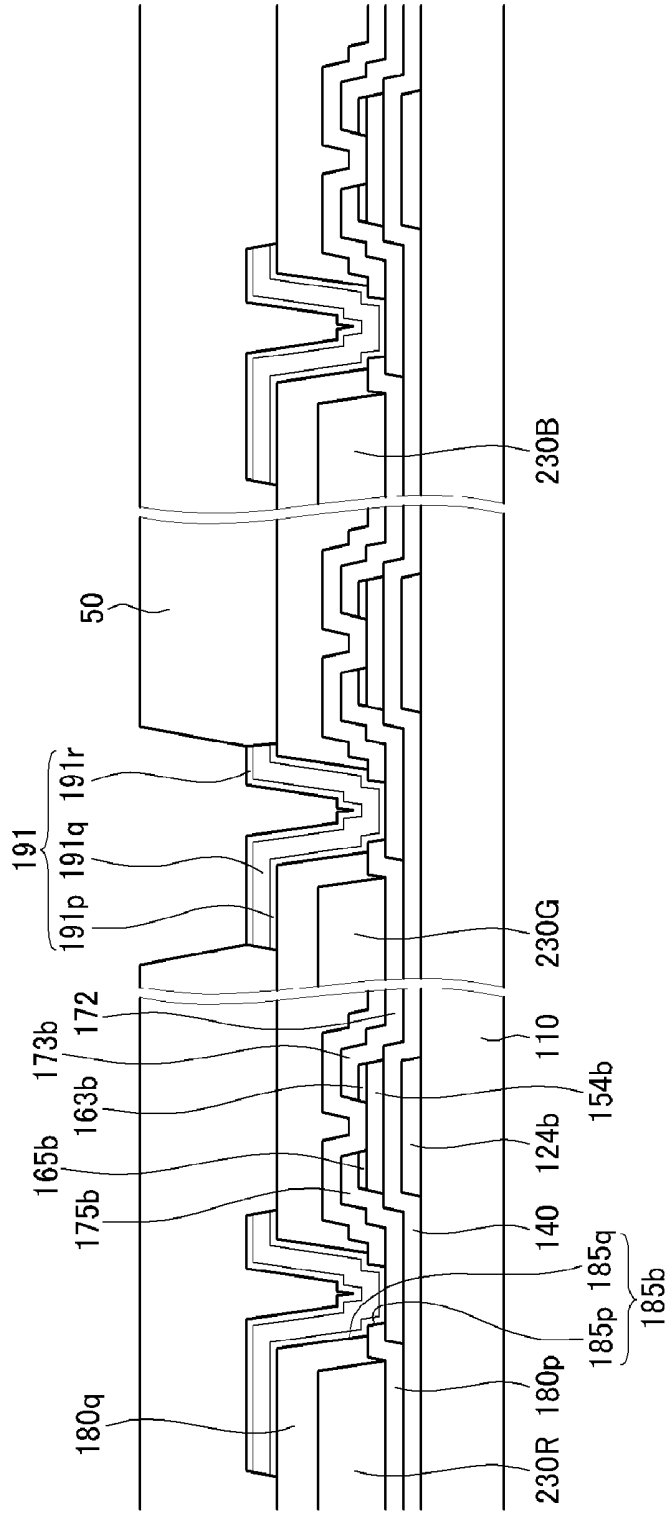

FIG. 23

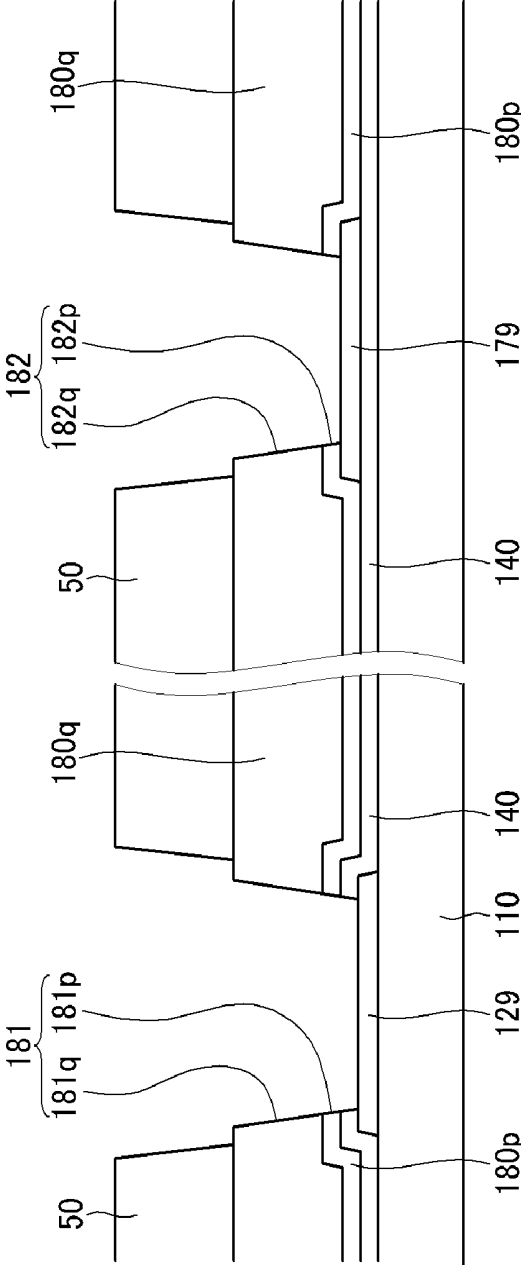

FIG. 24

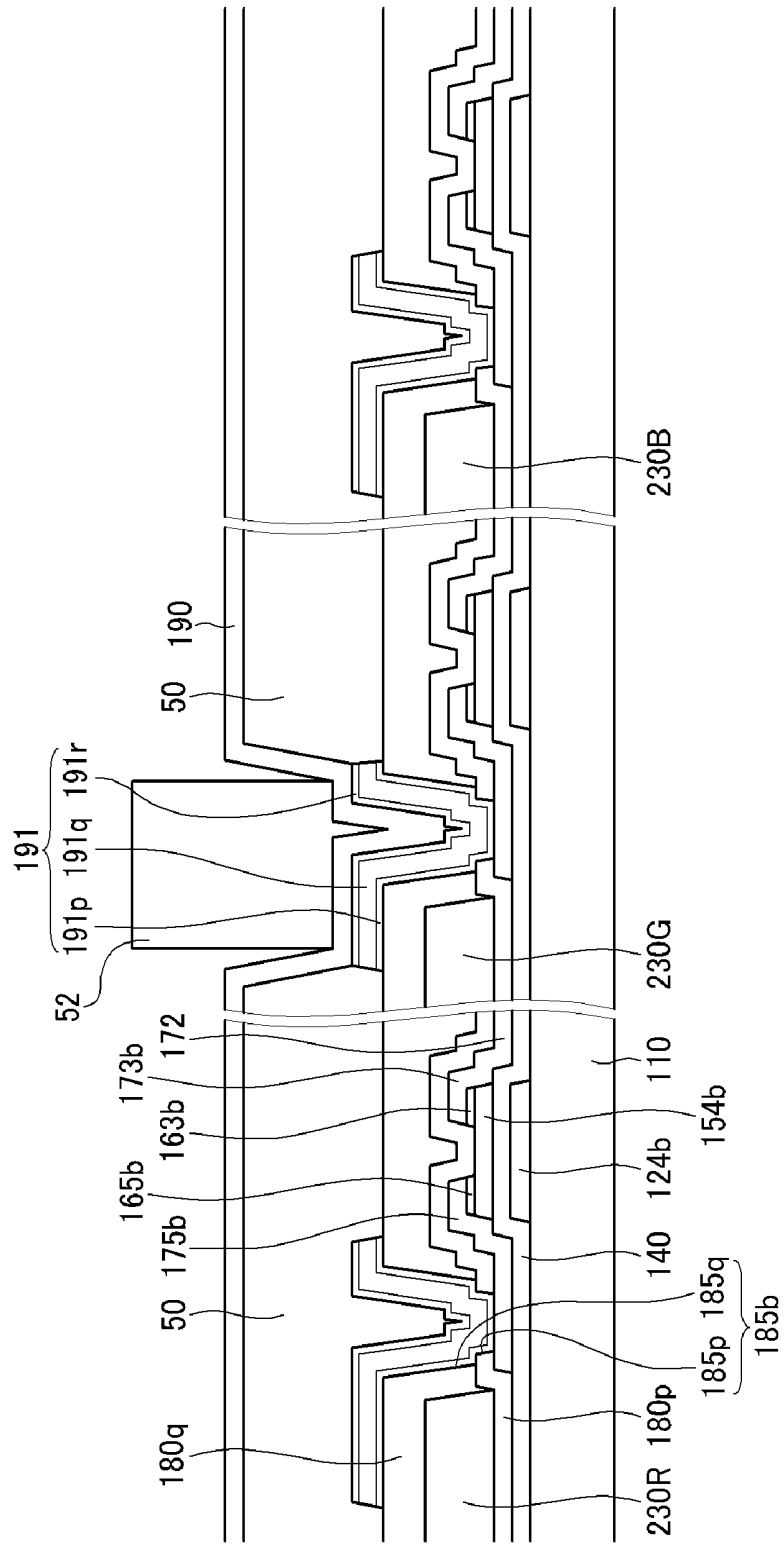

FIG. 25

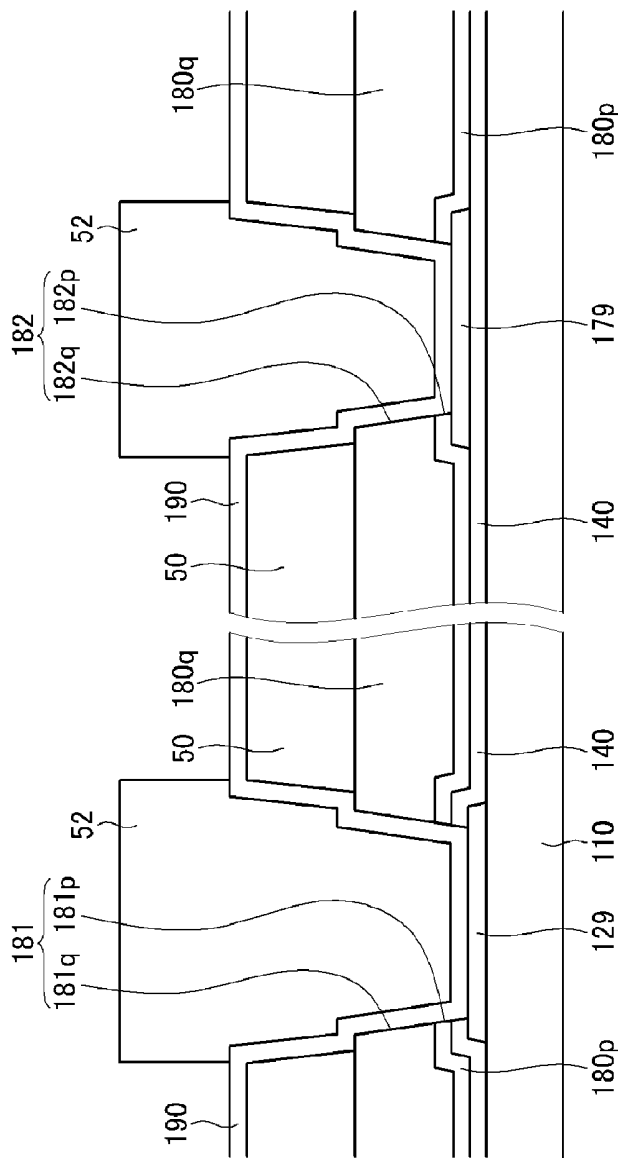



FIG. 27

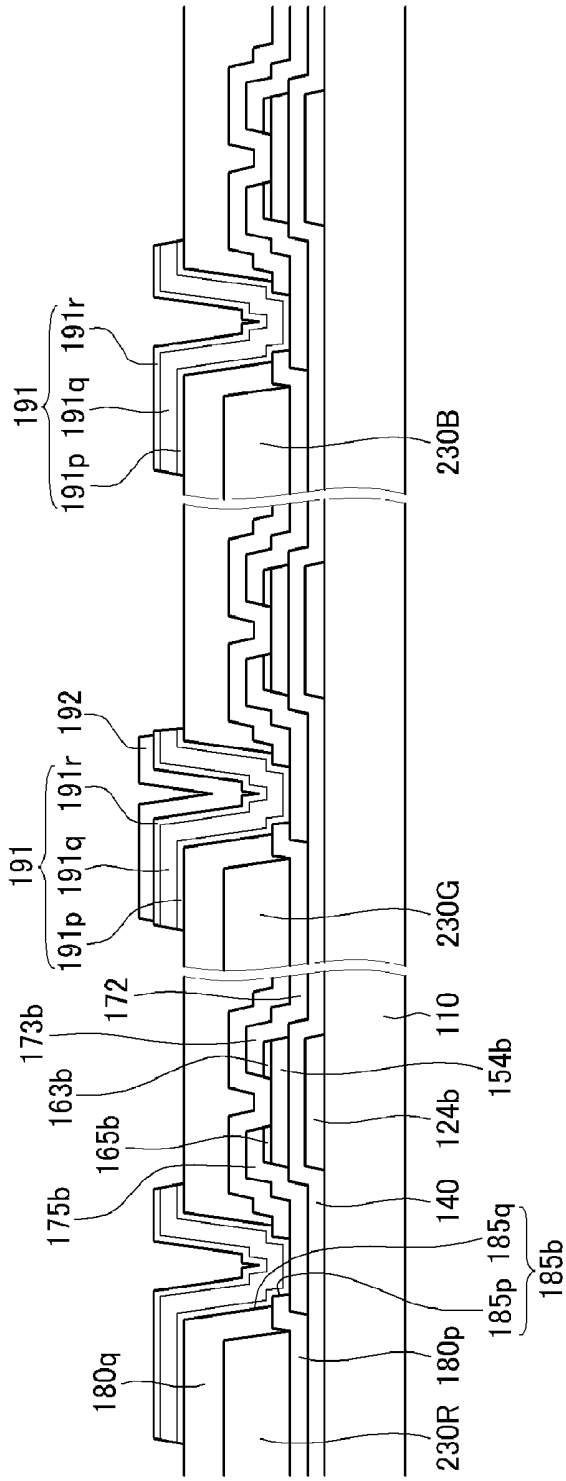
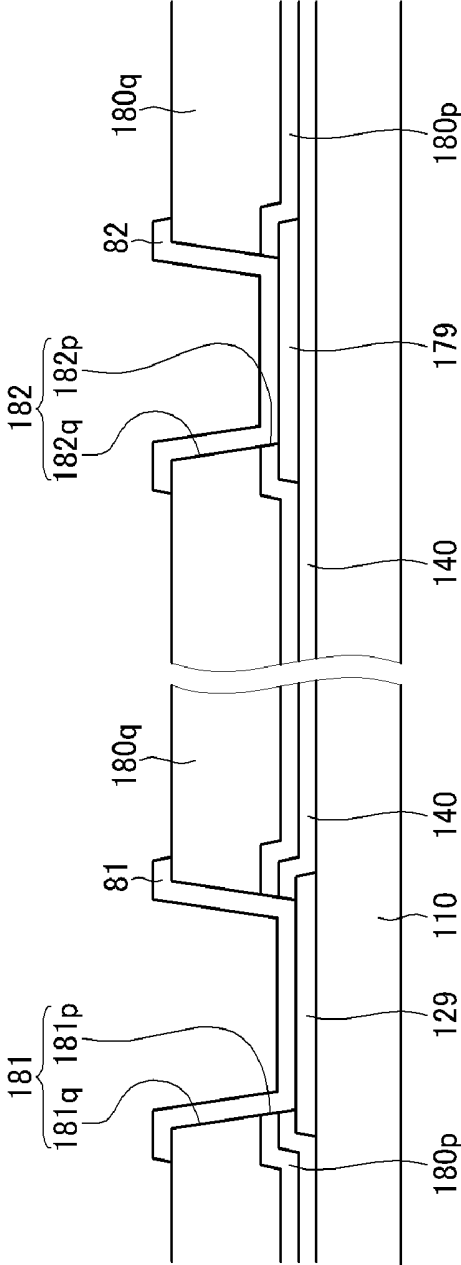

FIG. 28



**ORGANIC LIGHT EMITTING DIODE  
DISPLAY AND METHOD FOR  
MANUFACTURING THE SAME**

**CROSS REFERENCE TO RELATED  
APPLICATIONS**

[0001] This application is a divisional of U.S. patent application Ser. No. 12/420,546, filed on Apr. 8, 2009 and claims priority from and the benefit of Korean Patent Application No. 10-2008-0100140 filed on Oct. 13, 2008, all of which are hereby incorporated by reference for all purposes as if fully set forth herein.

**BACKGROUND OF THE INVENTION**

[0002] 1. Field of the Invention

[0003] The present invention relates to an organic light emitting device and a manufacturing method thereof.

[0004] 2. Discussion of the Background

[0005] An organic light emitting device includes two electrodes and an organic light emitting layer disposed between the two electrodes. One of the two electrodes injects holes and the other injects electrons into the light emitting layer. The injected electrons and holes combine to form excitons, which emit light as discharged energy.

[0006] Because an organic light emitting device is a self-emissive display device, an additional light source is not necessary. Thus, an organic light emitting device may have lower power consumption as well as high response speed, wide viewing angle, and high contrast ratio.

[0007] An organic light emitting device includes a plurality of pixels such as red pixels, blue pixels, green pixels, and white pixels. Full color images may be displayed by selectively combining these pixels.

[0008] Each pixel of an organic light emitting device includes an organic light emitting element and a plurality of thin film transistors for driving the organic light emitting element.

[0009] An organic light emitting element includes an anode and a cathode as its two electrodes, and an organic light emitting member as an emission layer disposed therebetween. The organic light emitting member may emit light of three primary colors such as red, green, and blue, or white light. The material of an organic light emitting member may be different according to the color of light emitted by the organic light emitting member. A method including stacking light emitting materials that emit red, green, and blue light, so that the synthesized light becomes white, may be used when the organic light emitting member emits white light. Moreover, in a case where the organic light emitting member emits white light, color filters may be added to obtain light of a desired color.

[0010] The thin film transistors include a switching transistor for switching a voltage applied to each pixel and a driving transistor for driving the organic light emitting element. The switching transistor may be connected to signal lines such as a scanning signal line, which transmits a scanning signal, and a data line, which transmits a data signal, and the various signals may be applied through pad portions located outside a display unit.

**SUMMARY OF THE INVENTION**

[0011] The present invention provides an organic light emitting device and a manufacturing method thereof.

[0012] Additional features of the invention will be set forth in the description which follows, and in part will be apparent from the description, or may be learned by practice of the invention.

[0013] The present invention discloses an organic light emitting device including: a plurality of scanning signal lines, each scanning signal line transmitting a scanning signal and comprising an end portion; a first contact assistant connected to the end portion of the scanning signal line; a plurality of data lines crossing the scanning signal lines, each data line transmitting a data signal and comprising an end portion; a second contact assistant connected to the end portion of the data line; a driving voltage line to transmit a driving voltage; and a first pixel, a second pixel, and a third pixel alternately arranged, wherein each first pixel, second pixel, and third pixel comprises a switching transistor connected to the scanning signal line and the data line, a driving transistor connected to the switching transistor and the driving voltage line, the driving transistor comprising an output terminal, a pixel electrode connected to the output terminal, the pixel electrode comprising at least two layers comprising a transfective electrode, an organic light emitting member arranged on the pixel electrode, and a common electrode arranged on the organic light emitting member, wherein the first pixel further comprises a supplementary member arranged on the pixel electrode, and wherein the first contact assistant and the second contact assistant each comprise the same material as the supplementary member.

[0014] The present invention also discloses a method of manufacturing an organic light emitting device, the method including: providing a substrate including a first region, a second region, and a third region; forming a plurality of signal lines on the substrate, each signal line including an end portion; forming a plurality of output electrodes on the substrate; forming a passivation layer on the signal lines and the output electrodes; forming a first contact hole by etching the passivation layer, the first contact hole exposing the output electrode; depositing a conductor layer on the passivation layer, the conductor layer including at least two layers including a transfective electrode layer; forming a first photosensitive film pattern on the conductor layer corresponding to the first region, the second region, and the third region; etching the conductor layer using the first photosensitive film pattern as a mask to remove the conductor layer at a position corresponding to the end portion of the signal line and to form a pixel electrode at each position corresponding to the first region, the second region, and the third region; removing the first photosensitive film pattern; forming a second photosensitive film pattern that exposes the pixel electrode at a position corresponding to one or two of the first region, the second region, and the third region, the second photosensitive film pattern covering the remaining pixel electrodes and exposing the passivation layer at a position corresponding to the end portion of the signal line; forming a second contact hole exposing the end portion of the signal line by etching the passivation layer using the second photosensitive film pattern as a mask; depositing a conductive supplementary member layer on the second photosensitive film pattern; and patterning the conductive supplementary member layer to form a supplementary member arranged on the pixel electrode not covered by the second photosensitive film pattern and to form a contact assistant that contacts the end portion of the signal line.

**[0015]** It is to be understood that both the foregoing general description and the following detailed description are exemplary and explanatory and are intended to provide further explanation of the invention as claimed.

#### BRIEF DESCRIPTION OF THE DRAWINGS

**[0016]** The accompanying drawings, which are included to provide a further understanding of the invention and are incorporated in and constitute a part of this specification, show exemplary embodiments of the invention, and together with the description serve to explain the principles of the invention.

**[0017]** FIG. 1 is an equivalent circuit diagram of an organic light emitting device in accordance with an exemplary embodiment of the present invention.

**[0018]** FIG. 2 is a layout view of three neighboring pixels of an organic light emitting device according to an exemplary embodiment of the present invention.

**[0019]** FIG. 3 and FIG. 4 are cross-sectional views of the organic light emitting device shown in FIG. 2 taken along lines III-III'-III''-III''' and IV-IV'-IV''-IV'''', respectively.

**[0020]** FIG. 5, FIG. 8, FIG. 13, FIG. 18, FIG. 21, and FIG. 26 are layout views showing intermediate steps of a manufacturing method of the organic light emitting device shown in FIG. 2, according to an exemplary embodiment of the present invention.

**[0021]** FIG. 6 and FIG. 7 are cross-sectional views of the organic light emitting device shown in FIG. 5 taken along lines VI-VI'-VI''-VI''' and VII-VII'-VII''-VII'''', respectively.

**[0022]** FIG. 9 and FIG. 10 are cross-sectional views of the organic light emitting device shown in FIG. 8 taken along lines IX-IX'-IX''-IX''' and X-X'-X''-X'''', respectively.

**[0023]** FIG. 11 and FIG. 12 are cross-sectional views of the organic light emitting device shown in FIG. 8 taken along lines IX-IX'-IX''-IX''' and X-X'-X''-X'''', and showing an intermediate step following that of FIG. 9 and FIG. 10.

**[0024]** FIG. 14 and FIG. 15 are cross-sectional views of the organic light emitting device shown in FIG. 13 taken along lines XIV-XIV'-XIV''-XIV''' and XV-XV'-XV''-XV'''', respectively.

**[0025]** FIG. 16 and FIG. 17 are cross-sectional views of the organic light emitting device shown in FIG. 13 taken along lines XIV-XIV'-XIV''-XIV''' and XV-XV'-XV''-XV'''', and showing an intermediate step following that of FIG. 14 and FIG. 15.

**[0026]** FIG. 19 and FIG. 20 are cross-sectional views of the organic light emitting device shown in FIG. 18 taken along lines XIX-XIX'-XIX''-XIX''' and XX-XX'-XX''-XX'''', respectively.

**[0027]** FIG. 22 and FIG. 23 are cross-sectional views of the organic light emitting device shown in FIG. 21 taken along lines XXII-XXII'-XXII''-XXII''' and XXIII-XXIII'-XXIII''-XXIII'''', respectively.

**[0028]** FIG. 24 and FIG. 25 are cross-sectional views of the organic light emitting device shown in FIG. 21 taken along lines XXII-XXII'-XXII''-XXII''' and XXIII-XXIII'-XXIII''-XXIII'''', and showing an intermediate step following that of FIG. 22 and FIG. 23.

**[0029]** FIG. 27 and FIG. 28 are cross-sectional views of the organic light emitting device shown in FIG. 26 taken along lines XXVII-XXVII'-XXVII''-XXVII''' and XXVIII-XXVIII'-XXVIII''-XXVIII'''', respectively.

#### DETAILED DESCRIPTION OF THE ILLUSTRATED EMBODIMENTS

**[0030]** The invention is described more fully hereinafter with reference to the accompanying drawings, in which

exemplary embodiments of the invention are shown. This invention may, however, be embodied in many different forms and should not be construed as is limited to the exemplary embodiments set forth herein. Rather, these exemplary embodiments are provided so that this disclosure is thorough, and will fully convey the scope of the invention to those skilled in the art. In the drawings, the size and relative sizes of layers and regions may be exaggerated for clarity. Like reference numerals in the drawings denote like elements.

**[0031]** It will be understood that when an element or layer is referred to as being "on" or "connected to" another element or layer, it can be directly on or directly connected to the other element or layer, or intervening elements or layers may be present. In contrast, when an element is referred to as being "directly on" or "directly connected to" another element or layer, there are no intervening elements or layers present.

**[0032]** An organic light emitting device according to an exemplary embodiment of the present invention will be described in detail below with reference to FIG. 1.

**[0033]** FIG. 1 is an equivalent circuit diagram of an organic light emitting device according to an exemplary embodiment of the present invention.

**[0034]** Referring to FIG. 1, an organic light emitting device according to the present exemplary embodiment includes a plurality of signal lines 121, 171, and 172, and a plurality of pixels PX connected thereto and arranged substantially in a matrix.

**[0035]** The signal lines include a plurality of scanning signal lines 121 to transmit a gate signal (or a scanning signal), a plurality of data lines 171 to transmit a data signal, and a plurality of driving voltage lines 172 to transmit a driving voltage. The scanning signal lines 121 extend in a row direction and are substantially parallel to each other, and the data lines 171 extend in a column direction and are substantially parallel to each other. Although the driving voltage lines 172 are shown as extending in a column direction, the driving voltage lines 172 may extend in a row direction or in a column direction, or may be formed in a matrix.

**[0036]** Each pixel PX includes a switching transistor Qs, a driving transistor Qd, a storage capacitor Cst, and an organic light emitting element LD.

**[0037]** The switching transistor Qs includes a control terminal, an input terminal, and an output terminal, in which the control terminal is connected to the scanning signal line 121, the input terminal is connected to the data line 171, and the output terminal is connected to the driving transistor Qd. The switching transistor Qs transmits the data signal received from the data line 171 to the driving transistor Qd in response to the scanning signal received from the scanning signal line 121.

**[0038]** The driving transistor Qd also includes a control terminal, an input terminal, and an output terminal, in which the control terminal is connected to the switching transistor Qs, the input terminal is connected to the driving voltage line 172, and the output terminal is connected to the organic light emitting element LD. The driving transistor Qd applies an output current  $I_{LD}$  of which the magnitude varies according to the voltage applied between the control terminal and the output terminal.

**[0039]** The capacitor Cst is connected between the control terminal and the input terminal of the driving transistor Qd. The capacitor Cst stores a data signal applied to the control terminal of the driving transistor Qd and maintains the stored data signal even after the switching transistor Qs is turned off.

[0040] The organic light emitting element LD is an organic light emitting diode (OLED), which may include an anode connected to the output terminal of the driving transistor Qd and a cathode connected to a common voltage Vss. The organic light emitting element LD emits light of which the intensity is varied according to the output current  $I_{LD}$  of the driving transistor Qd, to display an image. The organic light emitting element LD may include an organic material emitting light of at least one primary color such as red, green, and blue, or may include an organic material emitting white light. The organic light emitting device displays a desired image by a spatial sum thereof.

[0041] The switching transistor Qs and the driving transistor Qd each may be an n-channel field effect transistor (FET). However, at least one of the switching transistor Qs and the driving transistor Qd may be a p-channel FET. Moreover, the connection relationship among the transistors Qs and Qd, the storage capacitor Cst, and the organic light emitting element LD may be modified.

[0042] A structure of the organic light emitting device shown in FIG. 1 will be described in detail below with reference to FIG. 2, FIG. 3, and FIG. 4 as well as FIG. 1.

[0043] FIG. 2 is a layout view of three neighboring pixels of an organic light emitting device according to an exemplary embodiment of the present invention, and FIG. 3 and FIG. 4 are cross-sectional views of the organic light emitting device shown in FIG. 2 taken along lines III-III'-III''-III''' and IV-IV'-IV'', respectively.

[0044] Referring to FIG. 2, an organic light emitting device according to an exemplary embodiment of the present invention includes red pixels R for displaying red light, green pixels G for displaying green light, and blue pixels B for displaying blue light, which are sequentially and alternately disposed. Three pixels including the red pixel R, the green pixel G, and the blue pixel B form one group, and the group of pixels may be repeatedly arranged according to rows and/or columns. However, arrangement and shapes of the pixels may be variously changed.

[0045] The structures of the three pixels R, G, and B are substantially the same, and the same constituent elements are designated by the same reference numerals.

[0046] Referring to FIG. 2, FIG. 3, and FIG. 4, a plurality of gate conductors including a plurality of scanning signal lines 121 that include a plurality of first control electrodes 124a, and a plurality of second control electrodes 124b that include a plurality of storage electrodes 127, are disposed on an insulation substrate 110 made of a material such as transparent glass or plastic.

[0047] The scanning signal lines 121 transmit gate signals and extend substantially in the transverse direction. Each scanning signal line 121 includes an end portion 129 having a large area for contact with another layer or an external driving circuit, and the first control electrodes 124a extend upward from the scanning signal line 121. When a scan driver (not shown) for generating scanning signals is integrated onto the insulation substrate 110, the gate lines 121 may be directly connected to the scan driver.

[0048] The second control electrodes 124b are separated from the scanning signal line 121 and include storage electrodes 127 extending in the column direction.

[0049] A gate insulating layer 140, which may be made of silicon nitride (SiNx), silicon oxide (SiOx), or so on, is disposed on the gate conductors.

[0050] A plurality of first and second semiconductor islands 154a and 154b are formed on the gate insulating layer 140. The first semiconductor islands 154a are disposed on the first control electrodes 124a, and the second semiconductor islands 154b are disposed on the second control electrodes 124b.

[0051] A plurality of pairs of first ohmic contacts (not shown) and a plurality of pairs of second ohmic contacts 163b and 165b are respectively disposed on the first and second semiconductor islands 154a and 154b. The first ohmic contacts (not shown) are disposed as a pair on the first semiconductor island 154a, and the second ohmic contacts 163b and 165b are disposed as a pair on the second semiconductor island 154b.

[0052] A plurality of data conductors including a plurality of data lines 171, a plurality of driving voltage lines 172, and a plurality of first and second output electrodes 175a and 175b are disposed on the ohmic contacts 163b and 165b and on the gate insulating layer 140.

[0053] The data lines 171 transmit data signals and extend in the column direction, thereby crossing the scanning signal lines 121. Each data line 171 includes a plurality of first input electrodes 173a extending toward the first control electrodes 124a and an end portion 179 having a large area for contact with another layer or an external driving circuit. When a data driving circuit (not shown) for generating the data signals is integrated onto the insulation substrate 110, the data lines 171 may be directly connected to the data driving circuit.

[0054] The driving voltage lines 172 transmit driving voltages and extend in a column direction, thereby crossing the scanning signal lines 121. Each driving voltage line 172 includes a plurality of second input electrodes 173b extending toward the second control electrodes 124b, and the driving voltage line 172 includes a portion overlapping the storage electrodes 127.

[0055] The first and second output electrodes 175a and 175b are separated from each other, and are separated from the data lines 171 and the driving voltage lines 172. The first input electrodes 173a and the first output electrodes 175a oppose each other on the first control electrodes 124a, and the second input electrodes 173b and the second output electrodes 175b oppose each other on the second control electrodes 124b.

[0056] The first control electrode 124a, the first input electrode 173a, and the first output electrode 175a form the switching transistor Qs along with the first semiconductor island 154a, and the channel of the switching transistor Qs is formed in the first semiconductor island 154a between the first input electrode 173a and the first output electrode 175a. The second control electrode 124b, the second input electrode 173b, and the second output electrode 175b form the driving transistor Qd along with the second semiconductor island 154b, and the channel of the driving transistor Qd is formed in the second semiconductor island 154b between the second input electrode 173b and the second output electrode 175b. The width of the channel of the driving transistor Qd may be increased or the length of the channel may be decreased to increase the driving current.

[0057] The ohmic contacts 163b and 165b are only disposed between the underlying semiconductor islands 154a and 154b and the overlying data conductor, thereby reducing contact resistance therebetween. The first and second semiconductor islands 154a and 154b each have a portion that is exposed without being covered by the data conductor. This

exposed portion is between the first and second input electrodes **173a** and **173b** and the first and the second output electrode **175a** and **175b**.

[0058] A lower passivation layer **180p**, which may be made of an inorganic insulator such as silicon nitride or silicon oxide, is formed on the data conductors, the exposed semiconductor islands **154a** and **154b**, and the gate insulating layer **140**.

[0059] Red color filters **230R** at the red pixels R, green color filters **230G** at the green pixels G, and blue color filters **230B** at the blue pixels B are respectively disposed on the lower passivation layer **180p**. The color filters **230R**, **230G**, and **230B** may not be formed on portions where the first and second control electrodes **124a** and **124b** and the first and second semiconductor islands **154a** and **154b** are disposed. The lower passivation layer **180p** may prevent pigments of the color filters **230R**, **230G**, and **230B** from flowing into the exposed semiconductor islands **154a** and **154b**.

[0060] An upper passivation layer **180q** is disposed on the color filters **230R**, **230G**, and **230B**, and the lower passivation layer **180p**. The upper passivation layer **180q** may be made of is an organic material and may have a flat surface.

[0061] The lower passivation layer **180p** and the upper passivation layer **180q** have a plurality of contact holes **182p**, **182q**, **185p**, and **185q** respectively exposing the end portions **179** of the data lines **171**, and the first and second output electrodes **175a** and **175b**. The contact holes **182p** and **182q** form a data contact hole **182**, contact holes (not shown) exposing the first output electrode **175a** form a first contact hole **185a**, and the contact holes **185p** and **185q** form a second contact hole **185b**.

[0062] The lower passivation layer **180p**, the upper passivation layer **180q**, and the gate insulating layer **140** have a contact hole **184** exposing the second control electrode **124b** and contact holes **181p** and **181q** exposing the end portion **129** of the scanning signal line **121**. The contact holes **181p** and **181q** form a gate contact hole **181**.

[0063] A plurality of pixel electrodes **191** at the respective pixels R, G, and B, supplementary members **192** (corresponding to the green pixel G), a plurality of connecting members **85**, and a plurality of contact assistants **81** and **82** are disposed on the upper passivation layer **180q**.

[0064] Each pixel electrode **191** of the red, green, and blue pixels R, G, and B comprises a lower electrode **191p** and an upper electrode **191r** that may be made of a conductive metal oxide such as indium tin oxide (ITO) or indium zinc oxide (IZO), and includes a transfective metal electrode **191q** disposed between the lower and upper electrodes **191p** and **191r**. Also, a supplementary member **192** that may be made of a transparent conductive material such as ITO or IZO is disposed on the pixel electrode **191** of the green pixel G.

[0065] The transfective metal electrode **191q** may be made of a highly reflective metal such as silver (Ag) and aluminum (Al), and the thickness thereof may be in the range of about 50 Å-250 Å. As such, even when a metal is used, if the metal layer is thin enough, the metal layer has transfective characteristics so that incident light is both reflected and transmitted.

[0066] The lower and upper electrodes **191p** and **191r** are respectively disposed under and on the transfective metal electrode **191q**, which may thereby improve cohesiveness between the transfective metal electrode **191q** and another layer as well as prevent corrosion. The lower electrode **191p**

may protect the transfective metal electrode **191q** from oxygen or moisture that may flow from the upper passivation layer **180q**.

[0067] Alternatively, the pixel electrodes **191** may have a multilayer structure including three or more layers according to another exemplary embodiment. According to another exemplary embodiment, the lower electrode **191p** or the upper electrode **191r** of the pixel electrode **191** may be omitted.

[0068] The pixel electrodes **191** are connected to the second output electrode **175b** through the second contact hole **185b**.

[0069] The connecting members **85** are connected to the first output electrode **175a** and the second control electrode **124b** through the first contact hole **185a** and the contact hole **184**, respectively. The cross-sectional structure of the connecting member **85** of the pixels R, G, and B may be the same as the cross-sectional structure of the previously described pixel electrode **191**. The connecting member **85** of the green pixel G may have the same cross-sectional structure as that of the pixel electrode **191** and the supplementary member **192** of the green pixel G.

[0070] The contact assistants **81** and **82** are respectively connected to the end portion **129** of the scanning signal line **121** and the end portion **179** of the data line **171** through the contact holes **181** and **182**. As shown in FIG. 4, the contact assistants **81** and **82** may have a single-layered structure that may be made of a transparent conductive material such as ITO or IZO. In this case, the contact assistants **81** and **82** may be made of the same material as the supplementary member **192** of the green pixel G, and have the same thickness. The contact assistants **81** and **82** may improve adhesiveness between the end portions **129** and **179** of the scanning signal line **121** and the data line **171** and external devices, and protect them. In this way, the contact assistants **81** and **82** may have a single-layered structure made of ITO or IZO, differently from the cross-sectional structure of the pixel electrode **191**, such that contact resistance between the end portions **129** and **179** and the external device may be prevented from being increased and fluctuated. Also, the on-current Ion of the switching and driving transistors Qs and Qd may be prevented from being deteriorated, the characteristics of the transistors Qs and Qd may be stabilized, and display characteristics of an organic light emitting device may be improved.

[0071] Again referring to FIG. 2, FIG. 3, and FIG. 4, a white organic light emitting member **370** is disposed on the whole surface of the upper passivation layer **180q**, the pixel electrode **191**, and the supplementary member **192** (corresponding to the green pixel G). The white organic light emitting member **370** may have a structure including a plurality of organic materials emitting light of different primary colors.

[0072] A common electrode **270**, which transmits a common voltage Vss, is disposed on the whole surface of the organic light emitting member **370**. The common electrode **270** may be made of a reflective metal including calcium (Ca), barium (Ba), magnesium (Mg), aluminum (Al), and silver (Ag).

[0073] An encapsulation layer (not shown) may be formed on the common electrode **270**. The encapsulation layer encapsulates the organic light emitting member **370** and the common is electrode **270** such that external moisture and/or oxygen may be prevented from penetrating the organic light emitting device.

[0074] In the organic light emitting device of the present exemplary embodiment, the pixel electrode 191 of the red and blue pixels R and B or the supplementary member 192 of the green pixel G, the organic light emitting member 370, and the common electrode 270 form an organic light emitting element LD having the pixel electrode 191 or the supplementary member 192 as an anode, and the common electrode 270 as a cathode, or vice versa. Also, the storage electrode 127 and the driving voltage line 172 that overlap each other form a storage capacitor Cst.

[0075] The organic light emitting device emits light toward the insulation substrate 110 to display images. Light emitted toward the insulation substrate 110 from the organic light emitting member 370 passes through the supplementary member 192 (only corresponding to the green pixel G) and the upper electrode 191r, and arrives at the transmissive metal electrode 191q. The incident light is reflected near the transmissive metal electrode 191q toward the common electrode 270, and the common electrode 270 reflects the light again toward the transmissive metal electrode 191q. Accordingly, light reciprocating between the transmissive metal electrode 191q and the common electrode 270 is subjected to an optical process such as interference, and passes through the transmissive metal electrode 191q and the color filters 230R, 230G, and 230B to the outside if a predetermined condition is satisfied. This reciprocating and interference process is referred to as a microcavity effect. Through the microcavity effect, the intensity of light corresponding to a specific wavelength range may be enhanced.

[0076] Here, the optical path length of the microcavity is determined according to the thickness and the refractive indices of the thin films disposed between the transmissive metal electrode 191q and the common electrode 270 such that light of wavelengths corresponding to each of the primary colors may be enhanced by appropriately selecting the thickness and materials of the thin films. In the present exemplary embodiment, the thickness and the refractive indices of the upper electrode 191r and the organic light emitting member 370 of the red and blue pixels R and B may be selected so that intensity of light corresponding to red and blue wavelengths may be enhanced, and the thickness and refractive indices of the supplementary member 192 and the upper electrode 191r of the green pixel G may be selected so that intensity of light corresponding to green wavelengths may be enhanced. Accordingly, the desired optical characteristics may be obtained. For example, light having the desired range of wavelengths and color purity for each of the primary colors may be obtained, so that light emission efficiency and color reproducibility of an organic light emitting device may be improved.

[0077] In the present exemplary embodiment, when the transmissive metal electrode 191q is formed with a thin metal film, deviation of the thickness of the transmissive metal electrode 191q is so small that desired optical characteristics, for example deviation of color purity, may be reduced.

[0078] According to another exemplary embodiment, differently from the above-described embodiment wherein the green pixel G comprises the supplementary member 192, the red pixel R and the blue pixel B may comprise supplementary members (not shown) disposed on the pixel electrodes 191 and the green pixel G does not comprise any supplementary member. In this case, thickness and refractive indices of various thin films including the supplementary members may be appropriately selected so that light having the desired range of

wavelengths of and color purity for each of the primary colors of red, green and blue may be obtained.

[0079] A manufacturing method of the organic light emitting device will be described below with reference to FIG. 5, FIG. 6, FIG. 7, FIG. 8, FIG. 9, FIG. 10, FIG. 11, FIG. 12, FIG. 13, FIG. 14, FIG. 15, FIG. 16, FIG. 17, FIG. 18, FIG. 19, FIG. 20, FIG. 21, FIG. 22, FIG. 23, FIG. 24, FIG. 25, and FIG. 26 as well as FIG. 2, FIG. 3, and FIG. 4.

[0080] FIG. 5, FIG. 8, FIG. 13, FIG. 18, FIG. 21, and FIG. 26 are layout views showing intermediate steps of a manufacturing method of the organic light emitting device shown in FIG. 2 according to an exemplary embodiment of the present invention. FIG. 6 and FIG. 7 are cross-sectional views of the organic light emitting device shown in FIG. 5 taken along lines VI-VI'-VI''-VI''' and VII-VII'-VII'', respectively. FIG. 9 and FIG. 10 are cross-sectional views of the organic light emitting device shown in FIG. 8 taken along lines IX-IX'-IX''-IX''' and X-X'-X'', respectively. FIG. 11 and FIG. 12 are cross-sectional views of the organic light emitting device shown in FIG. 8 taken along lines IX-IX'-IX''-IX''' and X-X'-X'', respectively, and showing an intermediate step following that of FIG. 9 and FIG. 10. FIG. 14 and FIG. 15 are cross-sectional views of the organic light emitting device shown in FIG. 13 taken along lines XIV-XIV'-XIV''-XIV''' and XV-XV'-XV'', respectively. FIG. 16 and FIG. 17 are cross-sectional views of the organic light emitting device shown in FIG. 13 taken along lines XIV-XIV'-XIV''-XIV''' and XV-XV'-XV'', respectively, and showing an intermediate step following that of FIG. 14 and FIG. 15. FIG. 19 and FIG. 20 are cross-sectional views of the organic light emitting device shown in FIG. 18 taken along lines XIX-XIX'-XIX''-XIX''' and XX-XX'-XX'', respectively. FIG. 22 and FIG. 23 are cross-sectional views of the organic light emitting device shown in FIG. 21 taken along lines XXII-XXII'-XXII''-XXII''' and XXIII-XXIII'-XXIII'', respectively. FIG. 24 and FIG. 25 are cross-sectional views of the organic light emitting device shown in FIG. 21 taken along lines XXII-XXII'-XXII''-XXII''' and XXIII-XXIII'-XXIII'', respectively, and showing an intermediate step following that of FIG. 22 and FIG. 23. FIG. 27 and FIG. 28 are cross-sectional views of the organic light emitting device shown in FIG. 26 taken along lines XXVII-XXVII'-XXVII''-XXVII''' and XXVIII-XXVIII'-XXVIII''.

[0081] Referring to FIG. 5, FIG. 6, and FIG. 7, a gate conductor layer (not shown) made of a metal having low resistivity, such as an aluminum-containing metal, a silver-containing metal, and a copper-containing metal, is deposited by sputtering on an insulation substrate 110 made of transparent glass, and is patterned by photolithography to form a plurality of gate conductors including a plurality of scanning signal lines 121 including first control electrodes 124a and end portions 129, and a plurality of second control electrodes 124b including storage electrodes 127.

[0082] Next, a gate insulating layer 140 made of silicon nitride or silicon oxide is formed on the whole surface of the insulation substrate 110, and a semiconductor layer (not shown) of amorphous or crystallized silicon and a semiconductor layer (not shown) doped with an impurity are sequentially deposited by chemical vapor deposition and patterned by photolithography to form a plurality of first semiconductor islands 154a and a plurality of second semiconductor islands 154b, and a plurality of ohmic contact layers 164b.

[0083] Next, referring to FIG. 8, FIG. 9, and FIG. 10, a data conductor layer (not shown) is deposited by sputtering on the

gate insulating layer **140** and the ohmic contact layer **164b** and patterned by photolithography to form a plurality of data conductors including a plurality of data lines **171** each having first input electrodes **173a** and an end portion **179**, a plurality of driving voltage lines **172** each having second input electrodes **173b**, and a plurality of the first and second output electrodes **175a** and **175b**.

[0084] Next, the ohmic contact layer **164b** is etched using the data lines **171** and the first and second output electrodes **175a** and **175b** as an etching mask to form a plurality of pairs of first ohmic contact islands (not shown) and a plurality of pairs of second ohmic contacts **163b** and **165b**, and the channels between the first and the second semiconductor islands **154a** and **154b** are exposed.

[0085] Referring to FIG. **11** and FIG. **12**, an inorganic insulating material such as silicon nitride or silicon oxide is coated or deposited by chemical vapor deposition on the whole surface of the gate insulating layer **140**, the data conductors, and the exposed semiconductor islands **154a** and **154b** to form a lower passivation layer **180p**. Next, color filters **230R**, **230G**, and **230B** are formed on the lower passivation layer **180p**. The color filters **230R**, **230G**, and **230B** may be formed by a solution process such as spin coating or inkjet printing, or by deposition using a shadow mask.

[0086] Next, an upper passivation layer **180q** of an organic insulating material is deposited on the lower passivation layer **180p** and the color filters **230R**, **230G**, and **230B**, and the upper passivation layer **180q** is patterned to form a plurality of contact holes **181q**, **182q**, and **185q**, exposing the lower passivation layer **180p** by photolithography, and so on.

[0087] Next, referring to FIG. **13**, FIG. **14**, and FIG. **15**, a photosensitive film pattern (not shown) is formed to expose a portion of the lower passivation layer **180p** exposed by the contact holes **185q**, except for on the contact holes **181q** and **182q** disposed on the end portions **129** and **179** of the scanning signal lines **121** and the data lines **171**, and the exposed lower passivation layer **180p** is etched. Accordingly, contact holes (not shown) exposing the first output electrodes **175a**, contact holes **185p** exposing the second output electrodes **175b**, and contact holes (not shown) exposing the second control electrodes **124b** are formed in the lower passivation layer **180p**. Here, the gate insulating layer **140** is altogether etched to form the is contact holes (not shown) exposing the second control electrodes **124b**. The contact holes (not shown) in the lower and upper passivation layers **180p** and **180q** exposing the first output electrode **175a** form a first contact hole **185a**, and the contact holes **185p** and **185q** exposing the second output electrode **175b** form a second contact hole **185b**. Also, the contact holes (not shown) of the lower and upper passivation layers **180p** and **180q** and the gate insulating layer **140** exposing the second control electrode **124b** also form a contact hole **184**.

[0088] Here, the lower passivation layer **180p** disposed on the end portions **129** and **179** of the scanning signal lines **121** and the data lines **171** is not removed.

[0089] Referring to FIG. **16** and FIG. **17**, a lower electrode layer **190p** made of IZO or ITO, a transfective metal electrode layer **190q** made of a metal having high reflectivity such as silver or aluminum, and an upper electrode layer **190r** made of a material such as IZO or ITO are sequentially deposited on the upper passivation layer **180q**.

[0090] Next, a first photosensitive film pattern **49** is formed, which exposes the upper electrode layer **190r** disposed on the end portions **129** and **179** of the scanning signal lines **121** and

the data lines **171**, and covers the upper electrode layer **190r** of the red, green, and blue pixels R, G, and B.

[0091] Referring to FIG. **18**, FIG. **19**, and FIG. **20**, the lower electrode layer **190p**, the transfective metal electrode layer **190q**, and the upper electrode layer **190r** are etched using the first photosensitive film pattern **49** as an etching mask to form a plurality of pixel electrodes **191** including a plurality of lower electrodes **191p**, transfective metal electrodes **191q**, and upper electrodes **191r** respectively on the red, green, and blue pixels R, G, and B. Here, the lower electrode layer **190p**, the transfective metal electrode layer **190q**, and the upper electrode layer **190r** that are deposited on the end portions of the scanning signal lines **121** and the data lines **171** is removed by photolithography.

[0092] Referring to FIG. **21**, FIG. **22**, and FIG. **23**, a photosensitive film is coated on the upper passivation layer **180q** and the upper electrode **191r**, and is exposed to light and developed to form a second photosensitive film pattern **50** that exposes the upper electrode **191r** of the green pixel G, and exposes the contact holes **181q** and **182q** disposed on the end portions **129** and **179** of the scanning signal lines **121** and the data lines **171** as well as a surrounding portion of the upper passivation layer **180q**.

[0093] Next, the lower passivation layer **180p** and the gate insulating layer **140** exposed by the contact holes **181q** are etched by using the second photosensitive film pattern **50** and the upper passivation layer **180q** as a mask to form contact holes **181p** exposing the end portions **129** of the scanning signal lines **121**, thereby completing the gate contact holes **181**. Also, the lower passivation layer **180p** exposed by the contact holes **182q** is etched using the second photosensitive film pattern **50** and the upper passivation layer **180q** as a mask to form contact holes **182p** exposing the end portions **179** of the data lines **171**, thereby completing data contact holes **182**.

[0094] Referring to FIG. **24** and FIG. **25**, a conductive supplementary member layer **190** made of IZO or ITO is deposited by sputtering. Next, a third photosensitive film pattern **52** is formed, covering the conductive supplementary member layer **190** at positions corresponding to the upper electrode **191r** of the green pixel G and the gate contact holes **181** and the data contact holes **182** as well as the circumference thereof.

[0095] Referring to FIG. **26**, FIG. **27**, and FIG. **28**, the conductive supplementary member layer **190** is etched using the third photosensitive film pattern **52** as an etching mask to form supplementary members **192** of the green pixels G and contact assistants **81** and **82**. Next, the second and third photosensitive film patterns **50** and **52** are removed.

[0096] Alternatively, the second photosensitive film pattern **50** may be lifted off after depositing the conductive supplementary member layer **190** without formation of the third photosensitive film pattern **52** to form the supplementary members **192** of the green pixels G and the contact assistants **81** and **82**.

[0097] Differently from the present embodiment, the second photosensitive film pattern **50** may be formed to cover the upper electrode **191r** of the green pixel G and expose the upper electrodes **191r** of the red pixel R and the blue pixel B. Also, the third photosensitive film pattern **52** may be formed to cover the conductive supplementary member layer **190** at positions corresponding to the upper electrodes **191r** of the red and blue pixels R and B. Consequently, supplementary members (not shown) may be formed in the red and blue pixels R and B.

[0098] Finally, as shown in FIG. 2, FIG. 3, and FIG. 4, a white organic light emitting member 370 and a common electrode 270 are sequentially formed.

[0099] Accordingly, without additional photolithography processes, the contact assistants 81 and 82 contacting the end portions 129 and 179 of the scanning signal lines 121 and the data lines 171 may be formed with the same process as the supplementary members 192 of the green pixels G.

[0100] Further, without an additional photolithography process, the multilayers 191<sub>p</sub>, 191<sub>q</sub>, and 191<sub>r</sub> forming the pixel electrodes 191 may be removed on the end portions 129 and 179 of the scanning signal lines 121 and the data lines 171, and the contact assistants 81 and 82 comprising a single layer may be formed, so that a fluctuation and increase in the contact resistance at the end portions 129 and 179 may be avoided, and characteristics of the transistors of Qs and Qd and the organic light emitting device may be improved.

[0101] The present invention may be applied to organic light emitting devices having various structures.

[0102] According to exemplary embodiments of the present invention, display characteristics of an organic light emitting device and characteristics of transistors used therein may be improved, and color reproducibility and light efficiency of an organic light emitting device may be improved.

[0103] It will be apparent to those skilled in the art that various modifications and variation can be made in the present invention without departing from the spirit or scope of the invention. Thus, it is intended that the present invention cover the modifications and variations of this invention provided they come within the scope of the appended claims and their equivalents.

What is claimed is:

1. A method for manufacturing an organic light emitting device, the method comprising:

- providing a substrate comprising a first region, a second region, and a third region;
- forming a plurality of signal lines on the substrate, each signal line comprising an end portion;
- forming a plurality of output electrodes on the substrate;
- forming a passivation layer on the signal lines and the output electrodes;
- forming a first contact hole by etching the passivation layer, the first contact hole exposing the output electrode;
- depositing a conductor layer comprising at least two layers on the passivation layer, the at least two layers comprising a transfective electrode layer;
- forming a first photosensitive film pattern on the conductor layer corresponding to the first region, the second region, and the third region;
- etching the conductor layer using the first photosensitive film pattern as a mask to remove the conductor layer at a position corresponding to the end portion of the signal line and to form a pixel electrode at each position corresponding to the first region, the second region, and the third region;
- removing the first photosensitive film pattern;
- forming a second photosensitive film pattern exposing the pixel electrode at a position corresponding to one or two of the first region, the second region, and the third region, the second photosensitive film pattern covering the remaining pixel electrodes and exposing the passivation layer at a position corresponding to the end portion of the signal line;

forming a second contact hole by etching the passivation layer using the second photosensitive film pattern as a mask, the second contact hole exposing the end portion of the signal line;

depositing a conductive supplementary member layer on the second photosensitive film pattern; and  
 patterning the conductive supplementary member layer to form a supplementary member on the pixel electrode exposed by the second photosensitive film pattern and to form a contact assistant contacting the end portion of the signal line.

2. The method of claim 1, wherein patterning the conductive supplementary member comprises:
  - forming a third photosensitive film pattern covering the conductive supplementary member layer at a position corresponding to the pixel electrode exposed by the second photosensitive film pattern and covering the conductive supplementary member layer at a position corresponding to the second contact hole; and
  - etching the conductive supplementary member using the third photosensitive film pattern as a mask.
3. The method of claim 1, wherein patterning the conductive supplementary member comprises lifting off the second photosensitive film pattern.
4. The method of claim 1, wherein forming the passivation layer comprises:
  - forming a lower layer on the signal line and the output electrode; and
  - forming an upper layer on the lower layer.
5. The method of claim 4, wherein the lower layer comprises an inorganic material comprising silicon nitride or silicon oxide, and the upper layer comprises an organic material.
6. The method of claim 4, wherein forming the passivation layer further comprises forming a third contact hole exposing the lower layer corresponding to the output electrode and the end portion of the signal line by etching the upper layer.
7. The method of claim 6, wherein a boundary of the first contact hole is disposed within a boundary of the third contact hole.
8. The method of claim 4, further comprising:
  - forming a first color filter, a second color filter, and a third color filter on the lower layer before forming the upper layer, the first color filter, the second color filter, and the third color filter corresponding to the first region, the second region, and the third region, respectively.
9. The method of claim 1, wherein the conductive supplementary member comprises a transparent conductive material comprising indium tin oxide (ITO) or indium zinc oxide (IZO).
10. The method of claim 1, wherein the supplementary member and the contact assistant have the same thickness.
11. The method of claim 1, wherein the conductor layer further comprises a lower electrode layer arranged under the transfective electrode layer and an upper electrode layer arranged on the transfective electrode layer.
12. The method of claim 11, wherein the transfective electrode layer comprises a metal comprising silver or aluminum, and the lower electrode layer

and the upper electrode layer comprise a conductive metal oxide comprising ITO or IZO.

**13.** The method of claim **12**, wherein the transfective electrode layer has a thickness in a range of 50 Å-250 Å.

**14.** The method of claim **1**, further comprising:  
after forming the supplementary member and the contact assistant,  
forming an organic light emitting member on the pixel electrode and the supplementary member, and  
forming a common electrode on the organic light emitting member.

\* \* \* \* \*

专利名称(译)	有机发光二极管显示器及其制造方法		
公开(公告)号	<a href="#">US20140141681A1</a>	公开(公告)日	2014-05-22
申请号	US14/166508	申请日	2014-01-28
[标]申请(专利权)人(译)	三星显示有限公司		
申请(专利权)人(译)	三星DISPLAY CO. , LTD.		
当前申请(专利权)人(译)	三星DISPLAY CO. , LTD.		
[标]发明人	CHOI MIN HYUK YOU CHUN GI PARK JONG HYUN KWON YOUNG DONG KANG JIN HEE		
发明人	CHOI, MIN-HYUK YOU, CHUN-GI PARK, JONG-HYUN KWON, YOUNG-DONG KANG, JIN-HEE		
IPC分类号	H05B33/10		
CPC分类号	H05B33/10 H01L27/3211 H01L27/3276 H01L51/5206 H01L51/5215		
优先权	1020080100140 2008-10-13 KR		
其他公开文献	US8951083		
外部链接	<a href="#">Espacenet</a> <a href="#">USPTO</a>		

摘要(译)

有机发光器件及其制造方法本发明涉及有机发光器件及其制造方法。本发明公开了一种有机发光装置，包括：多条扫描信号线；第一和第二联系助理；多条数据线与扫描信号线交叉；驱动电压线；交替排列第一像素，第二像素和第三像素，每个像素包括：开关晶体管，包括输出端的驱动晶体管，连接到输出端的像素电极，像素电极包括至少两层包括透反电极，布置在像素电极上的有机发光构件，以及布置在有机发光构件上的公共电极，其中第一像素还包括布置在像素电极上的辅助构件，并且其中第一和第二接触助理包括与补充成员相同的材料。

